

Frezing in het kozijn voor sluitkorn haaksloot

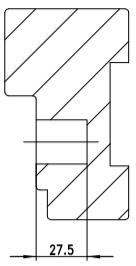

Haakschoot

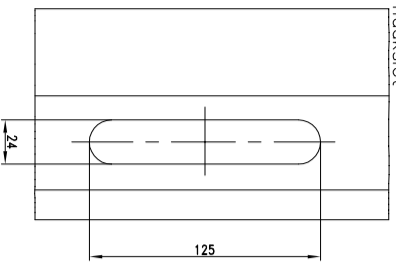
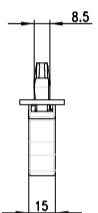
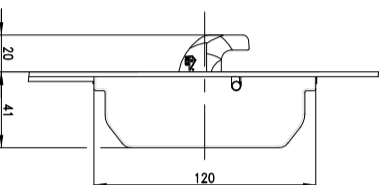

Frezing voor bijzet slotkast voor sluithaak

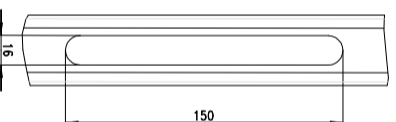
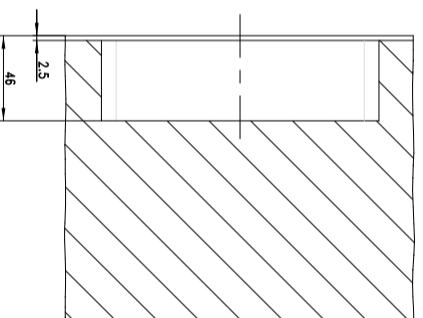

Sluithaak

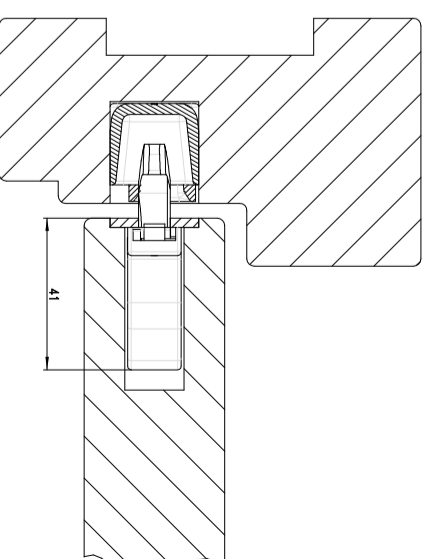

Frezing in kozijn voor sluitkorn hoofdsloot

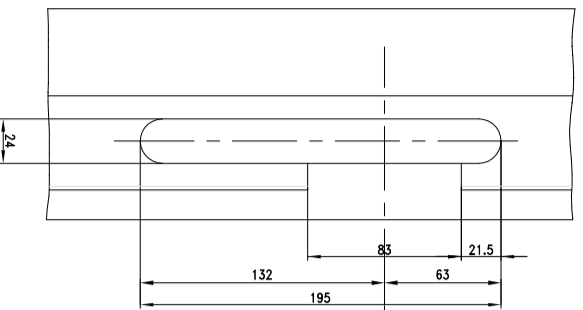

Maatvoering hoofdslootkast

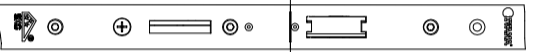
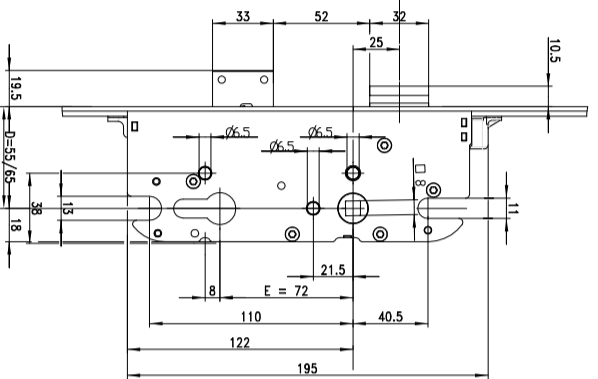

Krukbalhoogte 1050mm

Frezing voor de Hoofdslootkast

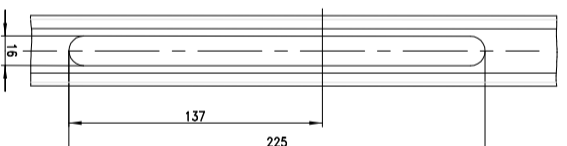
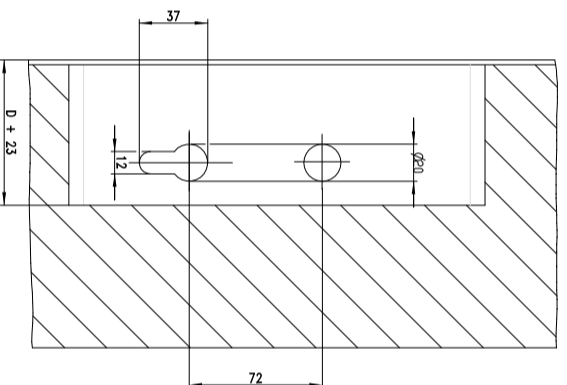

Doorsnede deur en kozijn

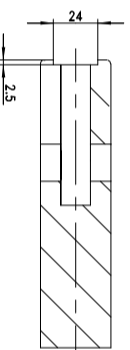
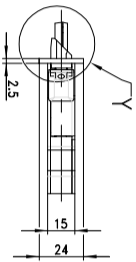
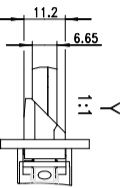
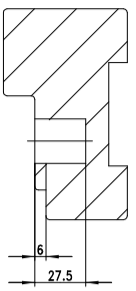
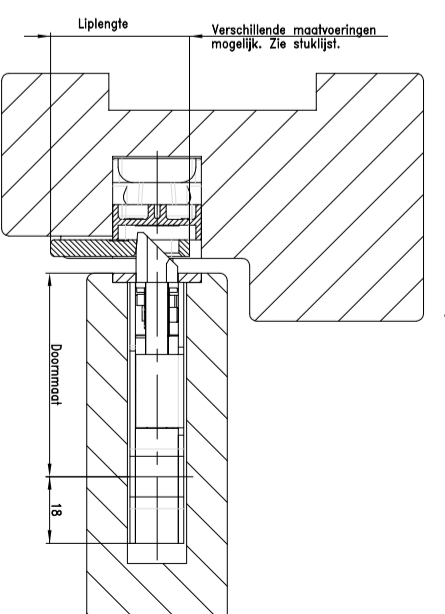

Description

IVANA MEERPUNTSLUITINGEN MET HAAKSCHOOT



Bestel nr.	In Work	Maakt	1
Werk nr.	Makelijng	1	
Datum	01.05.2018	MM	
Approved by			

HT06000